

Compact pressure switch Ex protection EEx-d, IP 65 Model PCA



WIKA data sheet PV 33.31



Applications

- Pressure monitoring and direct switching of electrical loads
- For measuring points with limited space
- For gaseous and liquid, aggressive and highly viscous or contaminated media, also in aggressive ambience
- Process industry: chemical/petro-chemical, on- and offshore, technical gases, environmental technology, machine building and general plant construction, water treatment, pharmaceutical industry
- Ignition protection type GAS Ex-d DUST Ex-tD Gr. II Cat. 1/2 GD

Special features

- Case flameproof enclosure
- Ingress protection IP 65, NEMA 4
- Ambient temperature -40 ... +85 °C
- 1 switch point, SPDT or DPDT with a high contact rating of up to 15 A / AC 220 V
- Setting ranges from 200 mbar, max. test pressure up to 250 bar

Description

These high-quality pressure switches have been specifically developed for safety-critical applications with limited space. High quality and product manufacturing to ISO 9001:2000 ensures reliable monitoring of your plant. In production, the switches are traced by quality assurance software at every step and subsequently are 100 % tested.

The gauge adapters are made of stainless steel, the diaphragm is, depending on the measuring range and the sensor code, made of Inconel or coated with NBR or PTFE. Each switch family is available in IP 65, Ex-ia or Ex-d versions (Ex-ia see model PCS, data sheet PV 33.30).



Compact pressure switch model PCA

In order to ensure as flexible operation as possible, the pressure switches are equipped with micro switches, which make it possible to switch an electrical load of up to 15 A / AC 220 V directly. For smaller contact ratings, such as for PLC applications, argon gas filled micro switches with gold-plated contacts can be selected as an option. For two separate circuits the switches are also available in the version DPDT (double change-over contact).

By using a diaphragm with an antagonist spring, the model PCA pressure switch is extremely robust and guarantees optimal operating characteristics at very high pressures.

Standard version

Case

Aluminium, epoxy resin coated,
case cover with screw-type cover, due to anti-twist device
secured against unauthorised intervention

Ingress protection

IP 65 per EN 60529 / IEC 529

Operating temperature

Ambient: -40 ... +85 °C

Medium:

Sensor code V and T: -30 ... +110 °C

Sensor code M: -30 ... +200 °C

Process connection

Stainless steel, lower mount (LM)

¼ NPT (female)

Measuring system

Diaphragm with antagonist spring

Wetted parts

Sensor code	Diaphragm 1)
V	NBR coating
T	PTFE coating
M	Inconel coating 2)

1) Diaphragm material depending on the setting range

2) With FPM O-ring

Switch contacts

Code	Type	Design	Electrical rating (resistive load) 4)	
			AC	DC
1	SPDT	Silver contacts	<u>15 A, 220 V</u>	2 A, 24 V 0.5 A, 125 V 0.25 A, 220 V
2 3)	DPDT	Silver contacts	<u>5 A, 220 V</u>	0.5 A, 24 V
3	SPDT	Silver contacts inert gas filled T _{amb} : -30 ... +70 °C	<u>15 A, 220 V</u>	2 A, 24 V 0.5 A, 220 V
4 3)	DPDT	Silver contacts hermetically sealed in air	<u>5 A, 220 V</u>	0.5 A, 24 V
5	SPDT	Gold-plated contacts inert gas filled T _{amb} : -30 ... +70 °C	<u>1 A, 220 V</u>	0.5 A, 24 V

3) Simultaneous triggering within 2% of span

4) Only the underlined data are shown on the product label

Repeatability

≤ 1 % of span

Setting ranges, max. test pressure, max. switch hysteresis

Sensor code	Setting range in bar	Working range in bar	Max. test pressure in bar	Max. switch hysteresis		
				Contact code 1, 3 and 5	Contact code 2	Contact code 4
V	-1 ... -0.2	-1 ... 6	10	30 mbar	30 mbar	120 mbar
T	0.2 ... 1.2	0 ... 6	10	30 mbar	30 mbar	120 mbar
M	0.5 ... 2.5	-1 ... 10	40	50 mbar	100 mbar	400 mbar
M	0.8 ... 6	-1 ... 10	40	60 mbar	200 mbar	800 mbar
M	1.6 ... 10	-1 ... 25	40	200 mbar	400 mbar	1.6 bar
M	4 ... 25	-1 ... 25	60	250 mbar	750 mbar	3 bar
M	10 ... 40	0 ... 100	160	4 bar	6 bar	10 bar
M	20 ... 100	0 ... 160	250	7 bar	9 bar	20 bar

Switch points

The switch points can be set to your requirements, free-of-charge.

Please specify:

Switch point, switching direction for each contact (e.g. switch point 1: 0.5 bar, falling, switch point 2: 3 bar, rising)

With two micro switches, the switch points can be set independently of each other.

After unscrewing the case cover, **switch point adjustment** can be made using the adjustment screw. The switch point is settable within the entire measuring range with **the following general rule:**

- Define the value $A = 2x \text{ repeatability} + \text{switch hysteresis}$
- If the pressure is rising, the switch point should be set between (min. + value A) up to max. of the setting range.
- If the pressure is falling, the switch point should be set between min. up to (max. - value A) of the setting range.

Example:

Setting range: 0 ... 1 bar with one switch contact

Repeatability: 1 % of 1 bar = 10 mbar

Switch hysteresis = 15 mbar (see table setting ranges)

Value $A = 2 \times 10 \text{ mbar} + 15 \text{ mbar} = 35 \text{ mbar}$

If the pressure is rising, the switch point should be set between 35 mbar up to 1 bar.

If the pressure is falling, the switch point should be set between 0 up to 965 mbar.

For optimal performance we suggest the switch point lies between 25 % and 75 % of the setting range.

Electrical connection

1/2 NPT female, cable connection using internal terminal block, ground connection using internal and external screw, max. ground cable cross-section 4 mm²

Pressure switch certified per:

- Pressure equipment directive 97/23/EC (PED, annex 1, category IV, safety accessories, module B + D)
- Low voltage directive 73/23 EEC and 93/68 EEC

Dielectric strength

Safety class I (EN 61 298-2: 1997-06)

Mounting

Direct or wall mounting

Preferred connection location of the process connection should be below. Alternatively the instrument can be installed so that access to internals is from front of the enclosure and the electrical connection is placed on side.

Weight

approx. 1.0 kg

Options

- Other process connection, also with adapter
- Case made of stainless steel 316
- Wiring 3/4 NPT, G 1/2 or M20 x 1.5 (female)
- Cable gland on request
- 2" pipe-mounting kit (with clamping element)
- Version for off-shore ⁵⁾ ⁶⁾ or tropicalised application ⁵⁾
- Version for applications to NACE ⁵⁾ ⁶⁾
- Version for ammonia applications ⁶⁾
- Oil and grease free version for oxygen applications
- Accessories:
 - Pressure gauge valves model 910.11, see data sheet AC 09.02
 - Barstock valves model 910.81, see data sheet AC 09.18

⁵⁾ Not in connection with sensor code V

⁶⁾ Inert gas filled contacts required

Approvals and certificates

- SIL 2 version ⁶⁾
- GOST-R certificate
- Test certificate *CA* (confirmation of the switching accuracy)
- Test report *CP* (3-time listing of the switch point, requires switch point specification)
- Material certificate 3.1 per EN 10204

Dimensions in mm

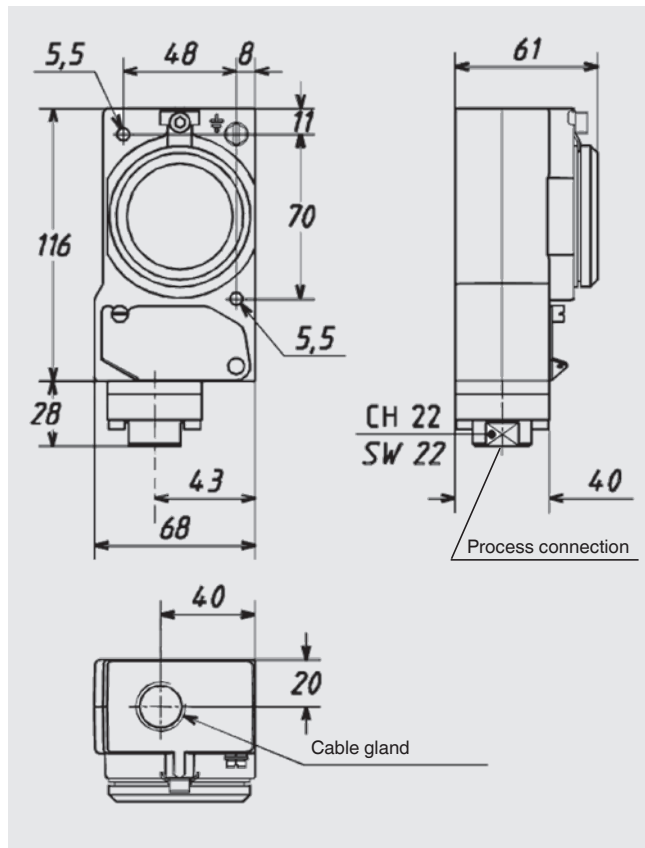

Ordering information

Model / Case / Sensor code / Switch contacts with version / Setting range / Process connection / Electrical connection / Switch point(s) / Switching direction(s) / Options

Example: PCA 2 M1 - 4/25 bar - 1/4"NPT-F - 1/2"NPT-F

The specifications given in this document represent the state of engineering at the time of publishing.
We reserve the right to make modifications to the specifications and materials.

