

Differential pressure switch Stainless steel version, IP 65 Model DW



WIKA data sheet PV 35.42



Applications

- Differential pressure monitoring and direct switching of electrical loads
- For gaseous and liquid, aggressive and highly viscous or contaminated media, also in aggressive ambience
- Process industry: chemical/petro-chemical, on- and offshore, technical gases, environmental technology, machine building and general plant construction, water treatment, pharmaceutical industry
- Pump monitoring and control / filter monitoring, level measurement in closed tanks

Special features

- Case made of stainless steel
- Ingress protection IP 65, NEMA 4
- Ambient temperature -30 ... +85 °C
- 1 or 2 independent switch points, high contact rating up to 15 A / AC 220 V
- Working pressure (static pressure) up to 160 bar



Differential pressure switch model DW

Description

These high-quality differential pressure switches have been developed especially for safety-critical applications. High quality and product manufacturing to ISO 9001:2000 ensures reliable monitoring of your plant. In production, the switches are traced by quality assurance software at every step and subsequently are 100 % tested.

All wetted parts materials are from stainless steel or Inconel 718, depending on the measuring range. Each switch family is available in IP 65, Ex-ia or Ex-d versions (Ex-d see model DA, data sheet PV 35.43).

In order to ensure as flexible operation as possible, the pressure switches are equipped with micro switches, which make it possible to switch an electrical load of up to 15 A / AC 220 V directly. For smaller contact ratings, such as for PLC applications, argon gas filled micro switches with gold-plated contacts can be selected as an option. By using a liquid-filled diaphragm measuring cell with fulcrum lever transmission, the model DW pressure switch is extremely robust and guarantees optimal operating characteristics.

Standard version

Case

Stainless steel,
case cover with bayonet lock, due to anti-twist device
secured against unauthorised intervention

Ingress protection

IP 65 per EN 60529 / IEC 529

Permissible temperature

Ambient: -30 ... +85 °C

Process connection

Stainless steel, lower mount (LM)
2 x ¼ NPT (female)

Measuring system

Double liquid-filled diaphragm measuring cell with fulcrum
lever transmission

Wetted parts

Process connection: Stainless steel 316
Diaphragm element: See table setting ranges ...
Sealing: NBR

Pressure ranges

Sensor code L: Low
Sensor code Z: Standard
Sensor code V: High

Max. working pressure (static pressure)

Either side
max. 40 bar Code: 040
max. 100 bar Code: 100
max. 160 bar Code: 160

Switch contacts

one or two SPDT (change-over) micro switches selectable,
DPDT function through two SPDT
micro switches with simultaneous
triggering within 0.5 % of span, in the
following variants:

| Code | Switch |
|------|----------|
| U | 1 x SPDT |
| D | 2 x SPDT |

| Code | Design | Electrical rating (resistive load) 2) | |
|-------------------------------------|---|---------------------------------------|---|
| | | AC | DC |
| Fixed switch hysteresis | | | |
| 1 | Silver contacts | <u>15 A, 220 V</u> | <u>2 A, 24 V</u> 0.5 A, 125 V 0.25 A, 220 V |
| 2 | Gold-plated contacts | <u>1 A, 125 V</u> | <u>0.5 A, 24 V</u> |
| 3 | Silver contacts inert gas filled Tamb: -30 ... +70 °C | <u>15 A, 220 V</u> | <u>2 A, 24 V</u> 0.5 A, 220 V |
| 4 | Gold-plated contacts inert gas filled Tamb: -30 ... +70 °C | <u>1 A, 125 V</u> | <u>0.5 A, 24 V</u> |
| Adjustable switch hysteresis | | | |
| 5 | Silver contacts 1) | <u>20 A, 220 V</u> | <u>2 A, 24 V</u> 0.5 A, 220 V |

1) Max. 1 switch contact

2) Only the underlined data are shown on the product label

Repeatability

≤ 1 % of span

Note

If the switch point is below 10 % of the span, the pressure switch should be mounted vibration-free in order to avoid any accidental switching.

Setting ranges, material of diaphragm element, max. switch hysteresis

| Sensor code | Setting range | Material of diaphragm element | Max. switch hysteresis | | | |
|-------------|-----------------|-------------------------------|------------------------|-------------------|---|-----------|
| | | | 1 switch contact | 2 switch contacts | 1 switch contact with settable hysteresis | |
| L | 0 ... 160 mbar | Stainless steel 316 | 5 mbar | 5 mbar | 20 ... | 60 mbar |
| L | 0 ... 250 mbar | Stainless steel 316 | 7.5 mbar | 7.5 mbar | 30 ... | 90 mbar |
| Z | 0 ... 400 mbar | Stainless steel 316 | 20 mbar | 20 mbar | 30 ... | 90 mbar |
| Z | 0 ... 600 mbar | Stainless steel 316 | 25 mbar | 25 mbar | 40 ... | 125 mbar |
| Z | 0 ... 1000 mbar | Stainless steel 316 | 30 mbar | 30 mbar | 100 ... | 270 mbar |
| Z | 0 ... 1000 mbar | Stainless steel 316 | 70 mbar | 70 mbar | 260 ... | 500 mbar |
| Z | 0 ... 4000 mbar | Stainless steel 304 | 120 mbar | 120 mbar | 350 ... | 900 mbar |
| Z | 0 ... 6000 mbar | Stainless steel 304 | 180 mbar | 180 mbar | 500 ... | 1200 mbar |
| Z | 0 ... 10 bar | Stainless steel 304 | 300 mbar | 300 mbar | 1000 ... | 3000 mbar |
| Z | 0 ... 16 bar | Inconel 718 | 480 mbar | 480 mbar | 1300 ... | 3200 mbar |
| Z | 0 ... 25 bar | Inconel 718 | 700 mbar | 700 mbar | 2000 ... | 5000 mbar |
| V | 0 ... 40 bar | Inconel 718 | 1200 mbar | 1200 mbar | - ... | - |

Switch points

The switch points can be set to your requirements, free-of-charge.

Please specify:

Switch point, switching direction for each contact (e.g. switch point 1: 0.5 bar, falling, switch point 2: 3 bar, rising)

With two micro switches, the switch points can be set independently of each other.

After unscrewing the case cover, **switch point adjustment** can be made using the adjustment screw. The switch point is settable within the entire measuring range with **the following general rule:**

- Define the value $A = 2 \times \text{repeatability} + \text{switch hysteresis}$
- If the pressure is rising, the switch point should be set between (min. + value A) up to max. of the setting range.
- If the pressure is falling, the switch point should be set between min. up to (max. - value A) of the setting range.

Example:

Setting range: 0 ... 1 bar with one switch contact

Repeatability: 1 % of 1 bar = 10 mbar

Switch hysteresis = 15 mbar (see table setting ranges)

Value $A = 2 \times 10 \text{ mbar} + 15 \text{ mbar} = 35 \text{ mbar}$

If the pressure is rising, the switch point should be set between 35 mbar up to 1 bar.

If the pressure is falling, the switch point should be set between 0 up to 965 mbar.

For optimal performance we suggest the switch point lies between 25 % and 75 % of the setting range.

Electrical connection

1/2 NPT female, cable connection using internal terminal block, protective conductor connection using internal and external screw, max. earth cable cross-section 4 mm²

Pressure switch certified per:

- Pressure equipment directive 97/23/EC (PED, annex 1, category IV, safety accessories, module B + D)
- Low voltage directive 73/23 EEC and 93/68 EEC

Dielectric strength

Safety class I (EN 61298-2: 1997-06)

Mounting

Direct or wall mounting

Preferred connection location of the process connection should be below.

Weight

approx. 6.2 kg

Options

- Other process connection, also with adapter
- Electrical connection 3/4 NPT, G 1/2, G 3/4 or M20 x 1.5 (female)
- Cable gland on request
- Plus/minus setting ranges (e.g. -200 ... +200 mbar)
- 2" pipe-mounting kit (with clamping element)
- Version for off-shore ³⁾ or tropicalised application ³⁾
- Version for applications to NACE ³⁾
- Version for ammonia applications ³⁾
- Oil and grease free version for oxygen applications
- Wetted parts made of Monel
- Design per
 - GAS Ex-ia IIC T6 and T4
 - Dust Ex-iaD A20 IP65 T85 and T135 ³⁾

Electrical characteristics: $U_i = 30 \text{ V}$

$I_i = 100 \text{ mA}$

$P_i = 0.75 \text{ W}$

$C_i = 0 \mu\text{F}$

$L_i = 0 \text{ mH}$

- Accessories:
 - Three-way or five-way valve

³⁾ Inert gas filled contacts required

⁴⁾ Max. 1 switch contact

Approvals and certificates

- SIL 2 version ³⁾ ⁴⁾
- GOST-R certificate
- Test certificate *CA* (confirmation of the switching accuracy)
- Test report *CP* (3-time listing of the switch point, requires switch point specification)
- Material certificate 3.1 per EN 10204

Dimensions in mm

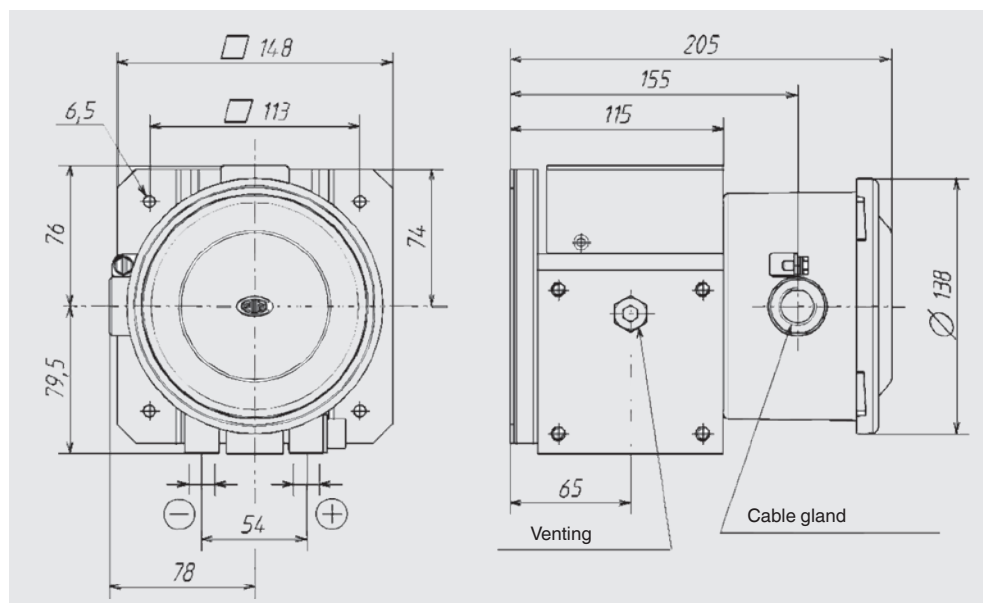

Ordering information

Model / Sensor code / max. working pressure (static pressure) / Switch contacts with version / Setting range / 2 x process connection / Electrical connection / Switch point(s) / Switching direction(s) / Options

Example: DW - L - 040 - U1 - 0/160 mbar - 2 x 1/4" NPT-F - 1/2" NPT-F

© 2011 WIKA Alexander Wiegand SE & Co. KG, all rights reserved.
The specifications given in this document represent the state of engineering at the time of publishing.
We reserve the right to make modifications to the specifications and materials.



WIKAL
WIKAL Alexander Wiegand SE & Co. KG
Alexander-Wiegand-Straße 30
63911 Klingenberg/Germany
Tel. (+49) 9372/132-0
Fax (+49) 9372/132-406
E-mail info@wika.de
www.wika.de