



Turbine Wheel Flow Meter/ Monitor

for Low Viscous Liquids



measuring
•
monitoring
•
analysing

DOT



- Measuring range:
0.11 - 1.1 m³/h ... 13.5 - 135 m³/h water
(higher on request)
- Viscosity range: low viscous
- Linearity: ±0.15 % ... ±0.5 % of reading
- p_{max}: 250 bar; t_{max}: 240 °C
- Connection:
G ½...G 2 male, ½" NPT...2" NPT male,
DIN flanges DN 15...DN 150 (larger on request),
ANSI flanges ½" ... 6" (larger on request)
- Material: Stainless steel, carbon steel
- Output: Pulses, LCD display, 4...20 mA,
batching, totalising



KOBOLD companies worldwide:

ARGENTINA, AUSTRIA, BELGIUM, BULGARIA, CANADA, CHILE, CHINA, COLUMBIA, CZECHIA,
DOMINICAN REPUBLIC, EGYPT, FRANCE, GERMANY, GREAT BRITAIN, HUNGARY, INDIA, INDO-
NESIA, ITALY, MALAYSIA, MEXICO, NETHERLANDS, PERU, POLAND, ROMANIA, SINGAPORE,
SOUTH KOREA, SPAIN, SWITZERLAND, TAIWAN, THAILAND, TUNISIA, USA, VIETNAM

KOBOLD Messring GmbH
Nordring 22-24
D-65719 Hofheim/Ts.
☎ Head Office:
+49(0)6192 299-0
☎ Sales DE:
+49(0)6192 299-500
☎ +49(0)6192 23398
info.de@kobold.com
www.kobold.com

Description

The turbine flowmeter model DOT consists of a helically shaped turbine rotor supported in two tungsten carbide bearings, the rotor being solid ferritic stainless steel of a grade compatible with the metered liquid, all contained within a housing of non-magnetic stainless steel.

A pick off coil having a permanent magnet core is mounted in the housing adjacent to the rotor blade tips such that a magnetic circuit is set up via the rotor blades (fig.1).

Rotation of the rotor varies the reluctance of this magnetic circuit and the flux changes induce a small voltage in the coil, the frequency of which is directly proportional to the rotor speed and therefore proportional to the volumetric flow rate.

The effects of increasing viscosity reduce the linear flow-range, the lower end flow rate is to be raised as the viscosity increases with a maximum viscosity of 10 mm²/s To calculate the low end accurate flow rate limit use: 0.7 x the square root of the metered liquid viscosity in mm²/s x normal minimum flow rate. Eg. If normal flow range is 10–100 L/min then for viscosity of 5 mm²/s time minimum accurate flow rate would be 15.65 L/min.

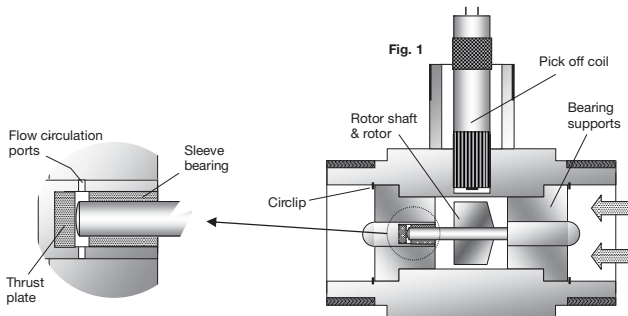

Design

The DOT is a highly accurate, reliable and robust turbine meter used to measure the flow of clean low viscosity liquids.

Stainless steel construction with tungsten carbide bearings provides long life with a wide range of aggressive and non-lubricating liquids in petrochemical and general industrial applications.

The basic meter is available with a frequency output (mV sine wave) or a pre-amplified square wave output (4 & 20 mA pulse). These meters have MS (military style) plug/socket for the pulse output connections. Alternatively the meter can be supplied fitted with integral instruments for harsh environments, to extend transmission distance or to interface with secondary instruments that require a conditioned signal input. These may include e.g. Z1 totaliser, Z3/Z5 flow rate totalisers or B1 batch controller.

If your meter is fitted with an instrument refer to the relevant instruction manual for details of the outputs and functions available.

Applications

- Chemical and allied products
- Pharmaceuticals
- Fuels
- Deionised water
- Fuel additives

Technical Details

Sizes:	15 mm... 150 mm (½" ... 6" ANSI, DN 15 ... DN 150), bigger on request (see model no. designation for information on available sizes)
Body material:	Stainless steel 1.4401 (316 SS)
Viscosity limit:	10 mm ² /s recommended maximum to maintain linear flow range
Linearity at 1cP:	±0.5 % of reading, ±0.15 % of reading optional for sizes 100 mm (4", DN100) and larger ±0.2% when utilising the linearisation feature of electronic type Z3
Repeatability:	±0.02 ... 0.05 % under steady flow conditions
Max. pressure:	DOT-xx05 ... DOT-xx25: 250 bar DOT-xx30: 50 bar, DOT-xx35: 40 bar DOT-xx40: 25 bar, DOT-xx45: 20 bar DOT-xx50: 13,3 bar Note: for flanged meters the actual max. operating pressure may be limited to a lower value due to applicable flange standard.
Temperature range:	-50 ... +120°C, optional 240°C max.
Pressure drop:	Approximately 0.28 bar at maximum flow (SG = 1.0, Vis. = 1 mm ² /s)
Supply voltage:	see electronics
Electronic features:	see comparison table
Flanges:	according to DIN2501 or ASME B16.5 (optional)
Materials	
Housing:	Stainless steel 1.4401 (316 SS)
Flanges:	Stainless steel 1.4401 (316 SS) or carbon steel A105
Rotor:	SS 430 (DOT-xxxxx4), SS ANC 21 (bigger sizes) or SS 316 for option "B"
Rotor shaft:	Tungsten carbide
Bearing support:	st. steel 1.4401 (316 SS)
Bearings:	Tungsten carbide sleeve
Thrust plate:	Tungsten carbide



Output

Standard: 2-wire reluctance type pick-off coil (40 mV P/P at minimum flowrate), polarity insensitive 20 metres maximum transmission distance

Preamplifier : Two wire 4mA (off) and 20 mA (on) current pulse (12 ... 24V_{DC}), 3000 metres maximum transmission distance

Other: see relevant electronics datasheet

Protection Class: IP66/67

Recommended Filters

Sizes up to 50 mm: 0.3 mm (300 microns or 60 mesh)

Sizes 80 mm bore and above: 0.5 mm (500 microns or 100 mesh)

Dimensions

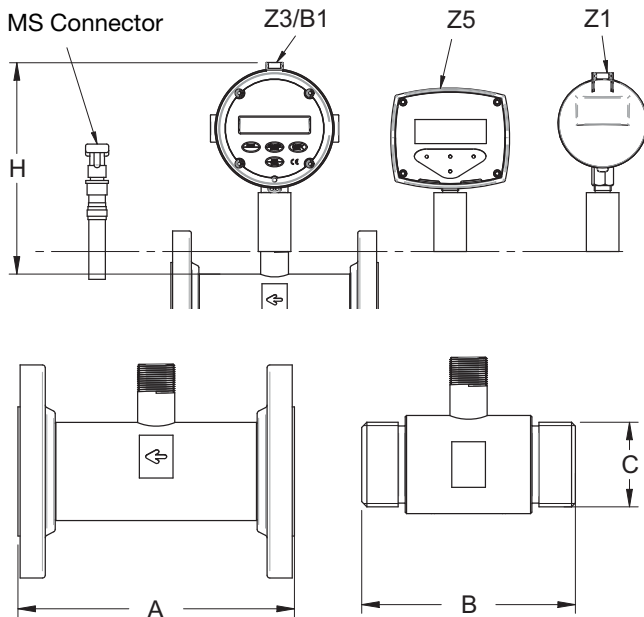

Electronic with LCD display

Model	--Z1	..Z3	..Z5	..B1
Function	dual totalizer	rate totalizer	rate totalizer	batch controller
Power source				
battery-powered	yes	yes	yes	no
external (drives output, backlighting)	8 - 24 V _{DC}	8 - 24 V _{DC}	8 - 24 V _{DC}	12 - 24 V _{DC}
LCD display				
-line 1 / no. of digits	7.5 mm/5	9 mm/8	17 mm/6	9 mm/8
-line 2 / no. of digits	3.6 mm/8	-	7 mm/8	-
selectable units	yes	yes	yes	yes
decimal point	yes	yes	yes	yes
subscripts displayed	yes	yes	yes	yes
accumulative total	yes	yes	yes	yes
resettable total	yes	yes	yes	no
linearisation	no	yes	no	no
rate display	no	yes	yes	no
backlighting	no	no	yes	no
Input type				
un-powered sensors	see ZOD datasheet			
powered sensors	see ZOD datasheet			
Outputs				
4-20 mA (750 Ω)	no	yes	no	no
high/low flow alarm	no	NPN/PNP	NPN	no
batch end & control	no	no	no	NPN/PNP
pulse outputs	NPN/PNP	NPN/PNP	NPN	NPN/PNP
2 x SPDT relays	no	optional*	no	optional*
Installation				
IP 66/67	yes	yes	yes	yes
cable entries	1 x gland (meter mount) 2 x glands (remote)	3 x M 20	3 x M 16	3 x M 20
intrinsic safe (option)	no	yes	no	no
mounting	meter mount, wall, pipe or panel mounting			
temperature range	-20 ... +80 °C (Option: -20 ... +120 °C)			

*replaces solid state outputs

Flanged meters

Option	A (mm)
DOT-xx05...	127
DOT-xx10...	127
DOT-xx15...	127
DOT-xx20...	140
DOT-xx25...	152
DOT-xx30...	178
DOT-xx35...	197
DOT-xx40...	254
DOT-xx45...	356
DOT-xx50...	368

Threaded meters

Model	B (mm)	C (mm)
DOT-xx05...	64	G ½ or NPT
DOT-xx10...	64	G ¾ or NPT
DOT-xx15...	64	G ¾ or NPT
DOT-xx20...	83	G ¾ or NPT
DOT-xx25...	89	G 1 or NPT
DOT-xx30...	115	G 1½ or NPT
DOT-xx35...	133	G 2 or NPT

Option	H (mm)
Z3/B1	210
Z5	185
Z1	190
M1/M2	118
M4	138

Pulse output (nominal)

Option	Pulses/litre
DOT-xx05...	4000
DOT-xx10...	1700
DOT-xx15...	1100
DOT-xx20...	400
DOT-xx25...	180
DOT-xx30...	60
DOT-xx35...	24
DOT-xx40...	15
DOT-xx45...	6.6
DOT-xx50...	2.3



Turbine Wheel Flow Meter/Monitor Model DOT

Order Details threaded version (Example: DOT-13 15 N5 F1 B1 0)

Housing/ connection material	Range	Mechanical Connection*	Pick-off style/ type	Electronics	Special Options
DOT-13 = (st. steel/ st. steel)	05 = 0.11 - 1.1 m³/h	G4 = ½" male	M1*** = MS (military style) connector for 120 °C max M2*** = MS (military style) connector for 240 °C max M4*** = MS (military style) connector preamplified, for 65 °C max F1** = Flying leads (compact meter mount, see electronics) for 120 °C max	00 = Frequency output only Z1 = Electronic ZOD-Z1 Z3 = Electronic ZOD-Z3 Z5 = Electronic ZOD-Z5 B1 = Electronic ZOD-B1	0 = none Y = Specified in clear text
	10 = 0.22 - 2.2 m³/h 15 = 0.4 - 4.0 m³/h 20 = 0.8 - 8 m³/h	G5 = ¾" male			
	25 = 1.6 - 16 m³/h	G6 = 1" male			
	30 = 3.4 - 34 m³/h	G8 = 1 ½" male			
	35 = 6.8 - 68 m³/h	G9 = 2" male			
	XX = special option	XX = special option			

* Replace DOT-xxxxGx... into DOT-xxxxNx... for NPT connection
 **only to be chosen with meter mount electronics Z1, Z3, Z5 or B1
 *** only to be chosen with frequency output "00"

Order Details flanged version (Example: DOT-13 50 FE F1 Z3 B)

Housing/ connection material	Range	Mechanical Connection***	Pick-off style/ type	Electronics	Special Options
DOT-12 = (st. steel/ carbon steel)	05 = 0.11-1.1 m³/h	F4* = DN 15, PN 16	M1***** = MS (military style) connector for 120 °C max M2***** = MS (military style) connector for 240 °C max M4***** = MS (military style) connector preamplified, for 65 °C max F1** = Flying leads (compact meter mount, see electronics) for 120 °C max	00 = Frequency output only Z1 = Electronic ZOD-Z1 Z3 = Electronic ZOD-Z3 Z5 = Electronic ZOD-Z5 B1 = Electronic ZOD-B1	0 = none B**** = Linearity 0.15% instead of 0.5% 2**** = 2x pick-offs 90° electrically offset Y = Specified in clear text
	10 = 0.22 - 2.2 m³/h 15 = 0.4 - 4.0 m³/h 20 = 0.8 - 8 m³/h	F5* = DN 20, PN 16			
	25 = 1.6 - 16 m³/h	F6* = DN 25, PN 16			
	30 = 3.4 - 34 m³/h	F8* = DN 40, PN 16			
	35 = 6.8 - 68 m³/h	F9* = DN 50, PN 16			
	40 = 13.5 - 135 m³/h	FB = DN 80, PN 16			
DOT-13 = (st. steel/ st. steel)	45 = 27 - 270 m³/h	FC = DN 100, PN 16	F1** = Flying leads (compact meter mount, see electronics) for 120 °C max	B1 = Electronic ZOD-B1	Y = Specified in clear text
	50 = 55 - 550 m³/h	FE = DN 150, PN 16			
	XX = special option	XX = special option	XX = special option	XX = sp. option	

* not available with DOT-12
 **only to be chosen with meter mount electronics Z1, Z3, Z5 or B1
 *** Change DOT-xxxxFx... into DOT-xxxxHx... for PN25
 Change DOT-xxxxFx... into DOT-xxxxAx... for ANSI 150 RF connection or into DOT-xxxxBx... for ANSI 300 RF
 ****only available for sizes DN100 and above
 ***** only to be chosen with frequency output "00"